

July 22



Acousto-Optic Modulator Driver

Including: Basic Modulator Alignment

Instruction Manual

RFA1x1 Series

Models -

RFA2x1-z

| | |
|---------|------------|
| x = 4 : | Fc = 40MHz |
| x = 5 : | Fc = 50MHz |
| x = 6 : | Fc = 60MHz |
| x = 7 : | Fc = 70MHz |
| x = 8 : | Fc = 80MHz |

Options -z:

- L : active low gate
(no connection = RF disabled)
- V : 0-5V analog modulation range
- A : analog modulation only. No gate signal
- D : digital modulation only. No gate signal
- R : coolant fittings on rear face

ISOMET CORP, 10342 Battleview Parkway, Manassas, VA 20109, USA.
Tel: (703) 321 8301, Fax: (703) 321 8546, e-mail: isomet@isomet.com

www.ISOMET.com

ISOMET (UK) Ltd, 18 Llantarnam Park, Cwmbran, Torfaen, NP44 3AX, UK.
Tel: +44 1633-872721, Fax: +44 1633 874678, e-mail: isomet@isomet.co.uk



1. GENERAL

The RFA2x1 is a combined Analog Driver and Power Amplifier is a fixed frequency RF power source specifically designed to operate with Isomet acousto-optic devices such as the M1208, M1346 and M1396. The driver accepts two independent modulating signals and provides a double-sideband amplitude modulated RF output to the acousto-optic modulator. A summary of the driver specification is shown in the following table:

| <u>Model</u> | <u>Center Frequency</u> | <u>Output Power</u> |
|--------------|-------------------------|---------------------|
| RFA141 | 40MHz | > 30.0 Watt |
| RFA151 | 50MHz | > 40.0 Watt |
| RFA181 | 80MHz | > 30.0 Watt |

Figure 2 is a functional block diagram of the driver. The center frequency of the driver is determined by the free-running quartz-crystal oscillator. This frequency and stability are accurate to within ± 25 ppm. The oscillator is not temperature stabilized.

A high-frequency, diode ring modulator is used to amplitude-modulate the RF carrier. The single turn potentiometer provides gain control for adjusting the peak RF power level when the modulation input is at maximum.

A solid-state RF switch provides a high-speed gate function. A TTL equivalent high level will gate the RF ON. The MMIC r-f pre-amplifier stage isolates the low-level modulation and control circuitry from the power amplifier stage.

The rise and fall times for the amplifier from either the modulation or the Gate input is near identical. Please refer to Table 1

The analog input level must not exceed 15 volts

The digital inputs must not exceed 7 volts

This amplifier is designed to operate at full rated power into a 50 Ω load with 100% duty cycle.



Water cooling is mandatory. The case temperature must not exceed 50°C.

**SERIOUS DAMAGE TO THE AMPLIFIER MAY RESULT IF THE TEMPERATURE EXCEEDS 70°C.
SERIOUS DAMAGE TO THE AMPLIFIER MAY ALSO RESULT IF THE RF OUTPUT CONNECTOR
IS OPERATED OPEN-CIRCUITED OR SHORT-CIRCUITED.**

A low impedance DC supply is required. The operating voltage is +24V (+28Vdc MAX) at a current drain of approximately 4A. Please refer to the model data sheet. The external power supply should be regulated to $\pm 2\%$ and the power supply ripple voltage should be less than 200mV for best results. Increased RF output power is achieved at 28Vdc.

The output power level is set by the power adjust potentiometer (PWR ADJ)

NOTE : Maximum power = fully clockwise

1.1 AO MODULATION OVERVIEW

To intensity modulate a laser beam in an acousto-optic modulator requires that the input RF carrier voltage (power) be varied according to the video or baseband information. From the viewpoint of intensity modulation, the deflection efficiency equation is normalized as:

$$i_1 = \text{Sin}^2 (kE_{RF})$$

where i_1 is the instantaneous intensity in the first order diffracted beam and E_{RF} is the instantaneous RF envelop voltage across the matched transducer.

In effect, the acousto-optic interaction demodulates the RF carrier, transforming the modulation envelop (baseband signal) into intensity variation of the first order diffracted laser beam.

Figure 7 shows the key modulator parameters

2 LED INDICATORS

The LEDs [C] and [D] illuminate when the DC power is applied, and the Interlocks are valid.

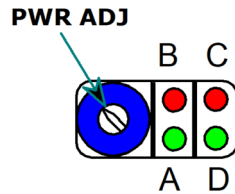

- [A] Shows GREEN when the RF output is live PROVIDED:
 - a) the modulation duty cycle is more than 20% (approx).
 - b) the RF CW power is > 20% (approx) of the driver maximum power
- [B] Not applicable – for future options
- [C] shows RED when the DC power is applied
- [D] shows GREEN when the (thermal) Interlocks are enabled

Caution, the RF output may be live even if these LED's are not illuminated.

LED Fault Conditions

The LEDs [C] and [D] will not illuminate if:

- a) the internal driver thermal interlock switch is open (over temperature fault).
- b) the AO thermal interlock switch is open (over temperature fault).
- c) the AO thermal interlock is not connected to the driver interlock input.
- d) the DC supply is off.

Standard over-temperature trip points

- RF driver: 50deg C
- AO device: 32deg C (Germanium) or 40degC (Quartz, Fused Silica).

The thermal interlocks will reset once the AO device and / or RF driver are cooled below the trip temperature. The hysteresis of the thermal switches is 7-10deg C. Once in a fault state, the coolant temperature may need to be reduced below the normal operating point to reset the thermal switches.

See AN1710 Resetting the AO Thermal Interlock (<https://isomet.com/appnotes.html>)

3. INSTALLATION AND ADJUSTMENT

3.1 Connect cooling water to the driver AND the AO device (e.g. M1208, M1396, M1346).

Use of a corrosion inhibitor is strongly advised.

Due to the high RF power dissipated in the AO modulators, it is paramount that the device is operated only when water cooling is circulating.

For optimum AO performance ensure the flow rate is more than 1 litre/minute at < 20 deg.C.

3.2 Connect the +24V (or +28V) and 0V DC supply to the feed-thru screw terminals as marked. See figure 1. Older versions may have a solder pin for +V and screw terminal for 0V. (See page 9). DO NOT turn on DC supply until step 3.10

3.3 Connect the RF output BNC jack to the acousto-optic modulator (or a high power 50Ω RF load, if it is desired to measure the modulator RF output power).

3.4 Connect the Interlock of the acousto-optic modulator (SMA, SMC or 'Binder719' 3pin snap connector) to the interlock inputs on the 9-pin D-type connector of the RFA. See page 8. Connect pin 4 of 'D'-type to INT+ and pin 5 to INT-

The interlock connection becomes open circuit disabling the RF output if the temperature exceeds the trip point. The trip point depends on the modulator type*: Germanium 32°C, Quartz 40degC, or if the internal driver temperature exceeds 50°C. An LED indicator illuminates when the Interlocks are good (closed) and the RF is enabled (see Section 2). In addition, a CMOS 'interlock valid' signal output is provided on pin 1 of the D-type connector for remote monitoring purposes.

3.5 Adjustment of the RF output power is best done with amplifier connected to the acousto-optic modulator. The amplifier output power is pre-set to approximately half maximum. (Refer to the test data sheet).

The optimum RF power level required for the modulator to produce maximum first order intensity will be different at various laser wavelengths. Applying RF power in excess of this optimum level will cause a decrease in first order intensity (a false indication of insufficient RF power) and make accurate Bragg alignment difficult. It is therefore recommended that initial alignment be performed at a low RF power level.



- 3.6 Locate the PWR ADJ access on the driver end plate.
- 3.7 With an insulated alignment tool or screwdriver rotate the PWR ADJ potentiometer fully anti-clockwise (CCW), then clockwise (CW) approx' 1/4 turn.
- 3.8 Connect pin 8 of the D-type to the modulation signal source and pin 9 to the (0V) return.
Apply a constant ON modulation signal:
 - Standard and Option -A models, the modulation is analog (A-mod): ON = 10V.
 - For Option -D models, the modulation is digital (D-mod): ON = High = 5V.
- 3.9 Apply a constant TTL high level to the digital gate input on the D-type connector.
Connect pin 6 to the signal source and pin 7 to the (0V) return.
Alternatively connect to a 5V DC supply if not actively used.
(This input is not required for -A or -D variants)
- 3.10 Apply DC power to the driver.

Input the laser beam toward the centre of either aperture of the AOM. Ensure the polarization is correct for the AO crystal type and the beam height does not exceed the active aperture height of the AOM. Refer to Figures 4,5,6, and appendix-A for beam alignment.

Start with the laser beam normal to the input optical face of the AOM and very slowly rotate the AOM (either direction).

- 3.11 Observe the diffracted first-order output from the acousto-optic modulator and the undeflected zeroth order beam. Adjust the Bragg angle (rotate the modulator) to maximise first order beam intensity.
- 3.12 After Bragg angle has been optimized, slowly increase the RF power (rotate PWR ADJ CW) until maximum first order intensity is obtained.
- 3.13 The driver is now ready for use. Figures 3 and 4 illustrate typical modulation characteristics.

* Standard values. Check specific model test data sheet



4. MAINTENANCE

4.1 Cleaning

It is of utmost importance that the optical apertures of the deflector optical head be kept clean and free of contamination. When the device is not in use, the apertures may be protected by a covering of masking tape. When in use, frequently clean the apertures with a pressurized jet of filtered, dry air.

It will probably be necessary in time to wipe the coated window surfaces of atmospherically deposited films. Although the coatings are hard and durable, care must be taken to avoid gouging of the surface and leaving residues. It is suggested that the coatings be wiped with a soft ball of brushed (short fibres removed) cotton, slightly moistened with clean alcohol. Before the alcohol has had time to dry on the surface, wipe again with dry cotton in a smooth, continuous stroke. Examine the surface for residue and, if necessary, repeat the cleaning.

4.2 Troubleshooting

No troubleshooting procedures are proposed other than a check of alignment and operating procedure. If difficulties arise, take note of the symptoms and contact the manufacturer.

4.3 Repairs

In the event of deflector malfunction, discontinue operation and immediately contact the manufacturer or his representative. Due to the high sensitive of tuning procedures and the possible damage which may result, no user repairs are allowed. Evidence that an attempt has been made to open the optical head will void the manufacturer's warranty.

Connection Summary: 9-way D-type

| Description Model | Variant | Signal | Type | Signal Pin | Return Pin | Level | Action |
|-------------------|----------------|----------------------|--------|------------|------------|----------------|----------|
| GATE | Standard | 5V Logic | Input | 6 | 7 | >1.7V | ON |
| | | | | | | <0.8V or NC | OFF |
| | Option -L | 5V Logic | Input | 6 | 7 | <0.8V | ON |
| | | | | | | >2.5V or NC | OFF |
| MODULATION | Standard | Analog, proportional | Input | 8 | 9 | 10V | Fully ON |
| | Option -A | Analog, proportional | Input | 8 | 9 | 10V | Fully ON |
| | Option -V | Analog, proportional | Input | 8 | 9 | 5V | Fully ON |
| | Option -D | Digital, 5V logic | Input | 8 | 9 | >2.5V | ON |
| | ALL modulation | | | Input | 8 | 9 | 0V |
| INTERLOCK | All | 15V Logic | Input | 4 | 5 | Closed contact | ON |
| | | | | | | Open / NC | OFF |
| Monitor | All | 15V Logic | Output | 1 | 2 | 15V | OK |
| | | | | | | < 1V | Fault |

NC = Not Connected

SEE NOTE NEXT PAGE, minimum connections shown below:

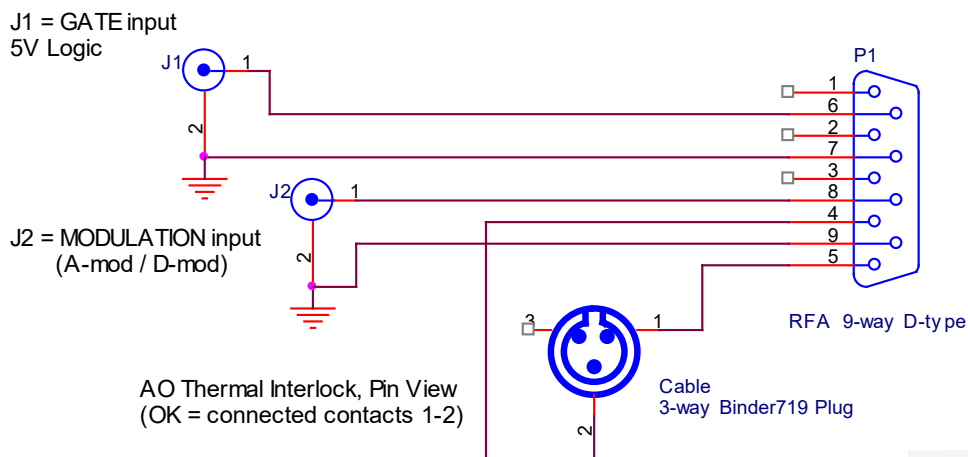

Binder 719 connector pin assignment

*Either pin is permitted. Isolated thermostatic switch in AO.

| Cable Connector Binder719 – 3way | | Driver D-type 9way |
|-------------------------------------|----|-----------------------|
| Pin1 | to | Pin5 (or Pin4*) |
| Pin2 | to | Pin4 (or Pin5*) |

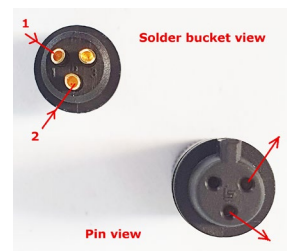

Binder 719 3-way cable connector (supplied)



Note:

Unless stated, both **Digital GATE** and **Analog Modulation** signals need to be applied.

The interlock signal must be connected. Contacts closed for normal operation.

Legacy design, DC supply connection

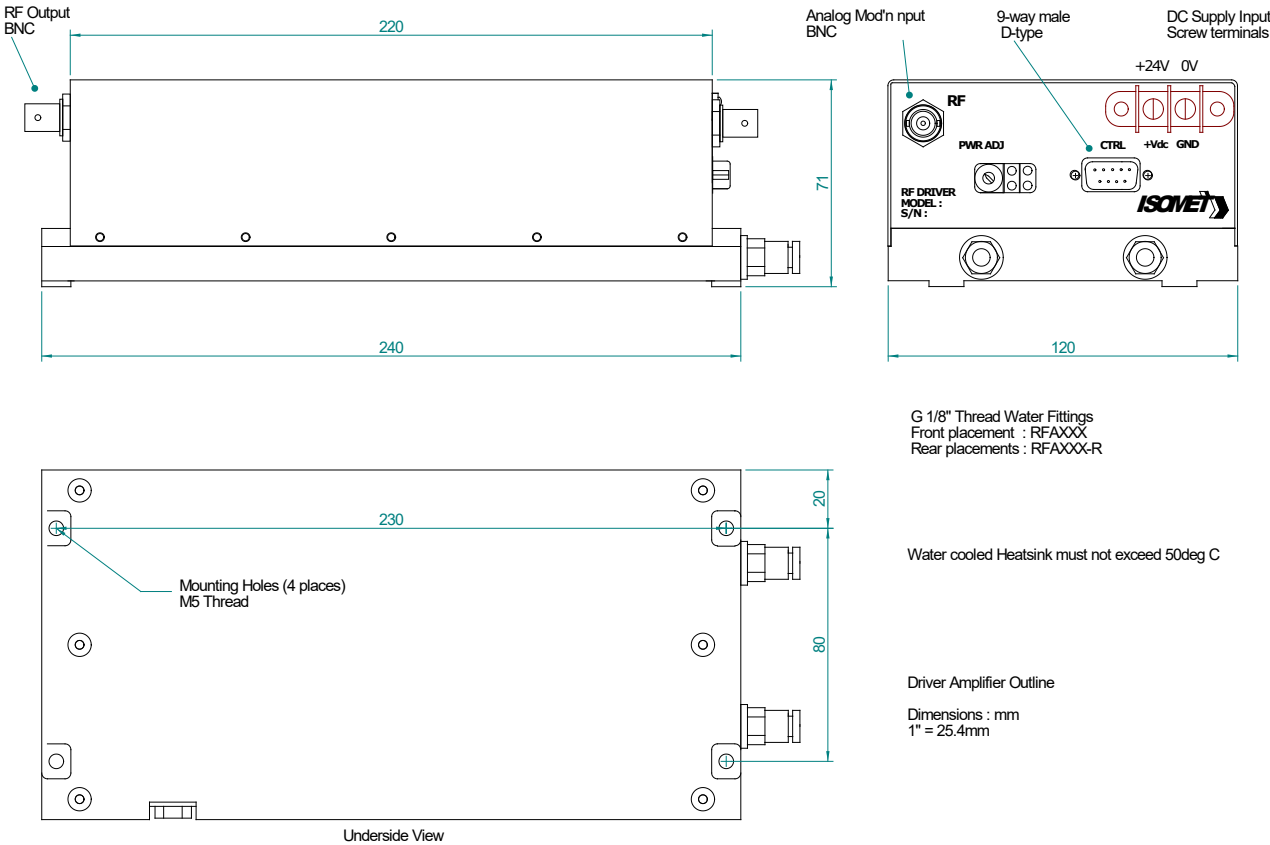
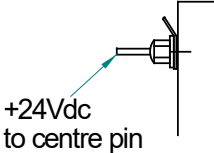

Figure 1: Driver Installation, mounting holes: 4 x M5

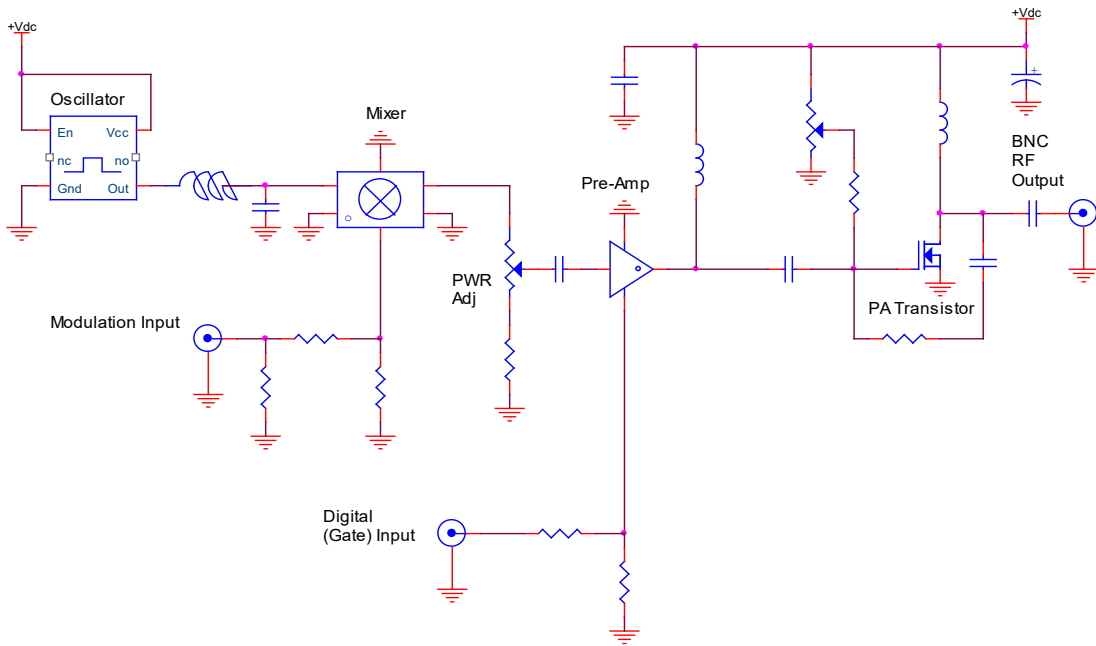

Figure 2: Driver Block Diagram

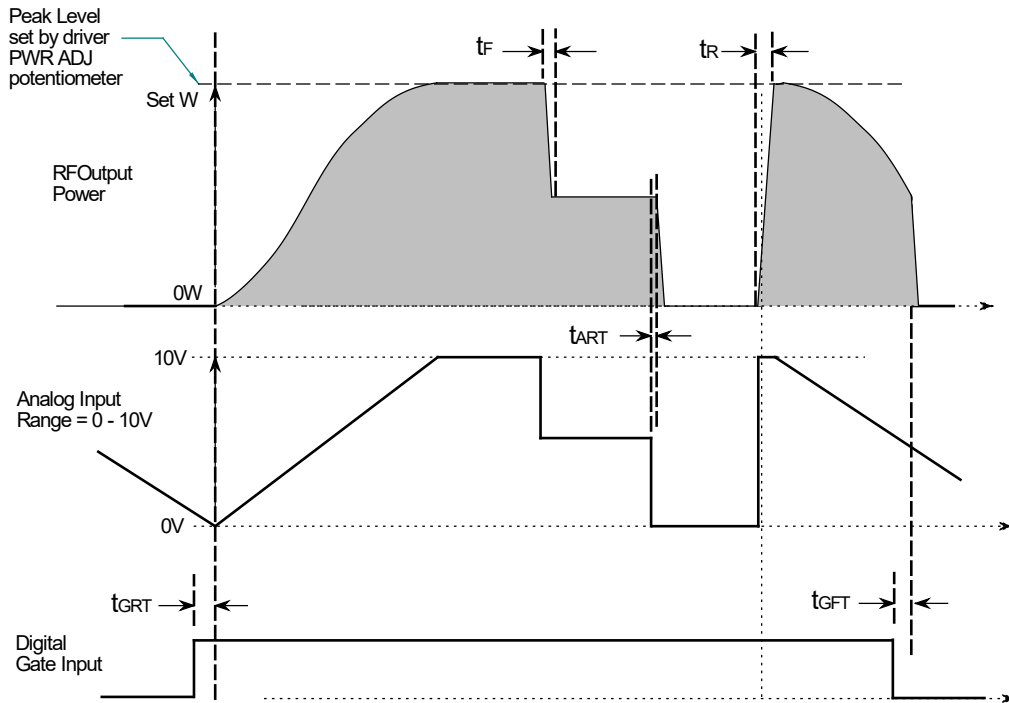

Figure 3: Typical RF Output Waveforms: Standard and Option -A models

The RF output waveform is a combination of the Modulation and Gate control inputs as illustrated above. Analog modulation shown.

| | Description | Variant | | |
|-----------|--|----------|---------|---------|
| | | Standard | -A | -D |
| t_R | RF rise time resulting from large signal modulation. | <150 ns | <150 ns | <150 ns |
| t_F | RF fall time resulting from large signal modulation. | <50 ns | <50 ns | <50 ns |
| t_{ART} | Latency delay between a change in modulation level (A-Mod or D-mod) and RF output. | 60 ns | 60 ns | 60 ns |
| t_{GRT} | Latency delay between a Gate High input and RF output fully enabled. | 200 ns | NA | NA |
| t_{GFT} | Latency delay between a Gate Low input and RF output fully disabled. | 100 ns | NA | NA |

Table 1: Timing spec's:

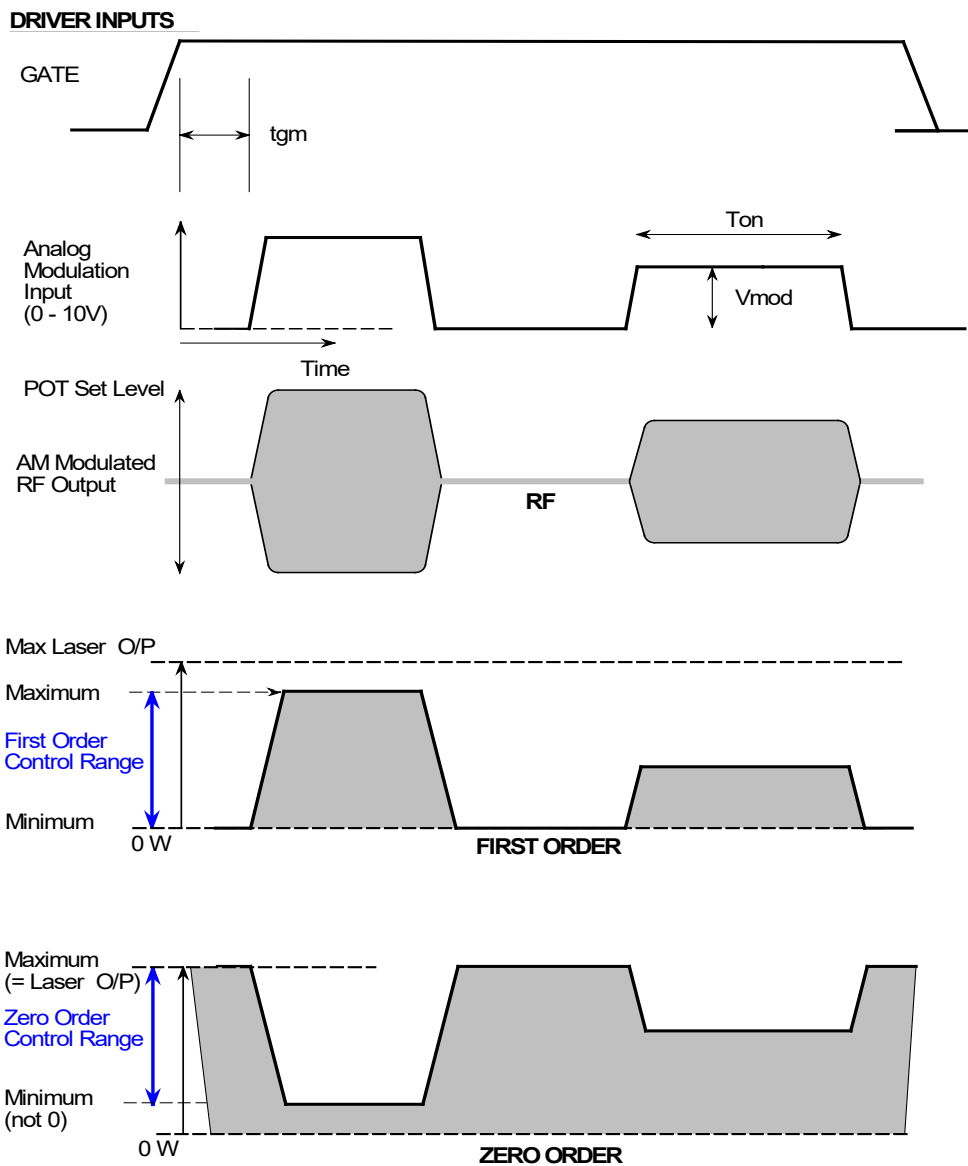

Figure 4: Illustration of Laser Beam Modulation and RF driver controls

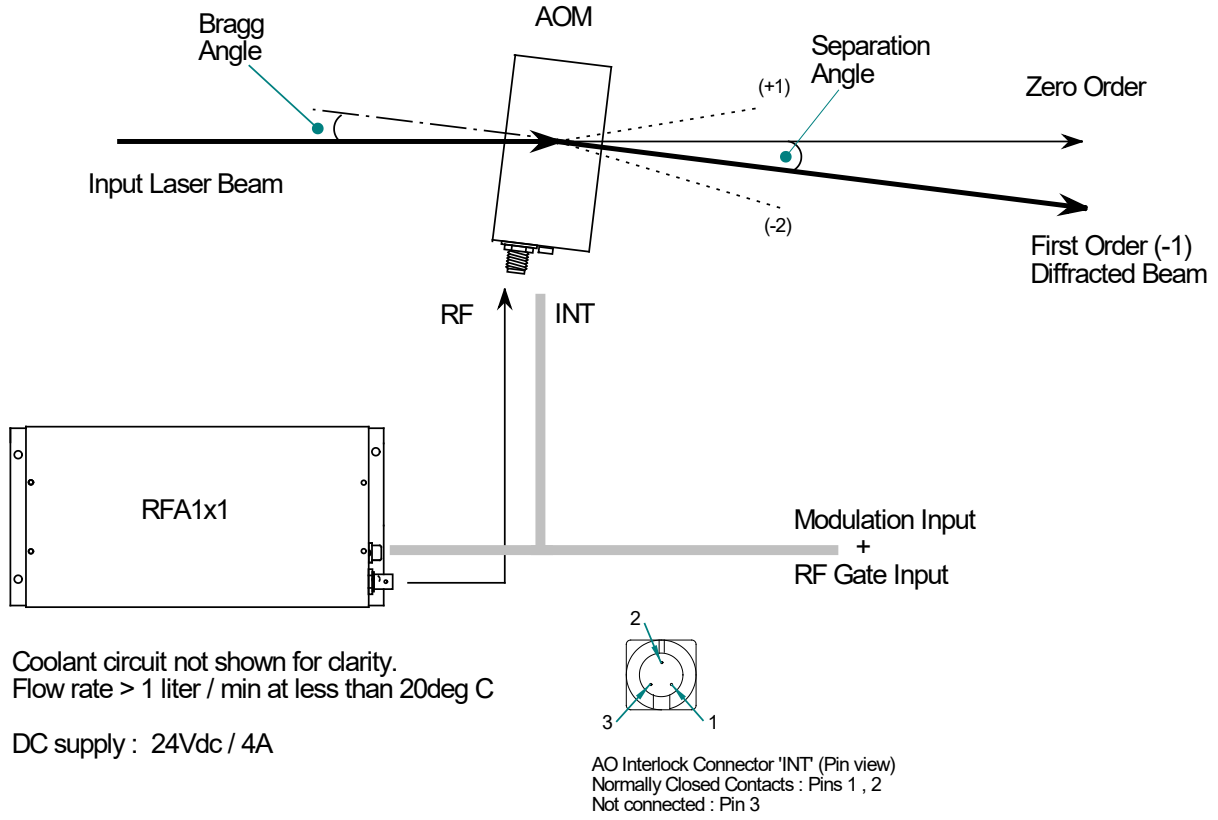

Figure 5: Typical Connection Configuration

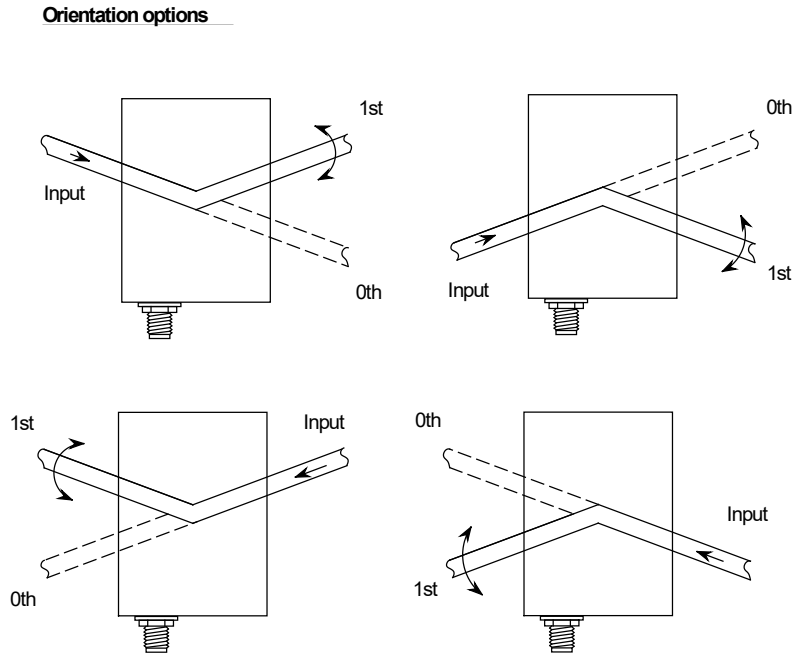
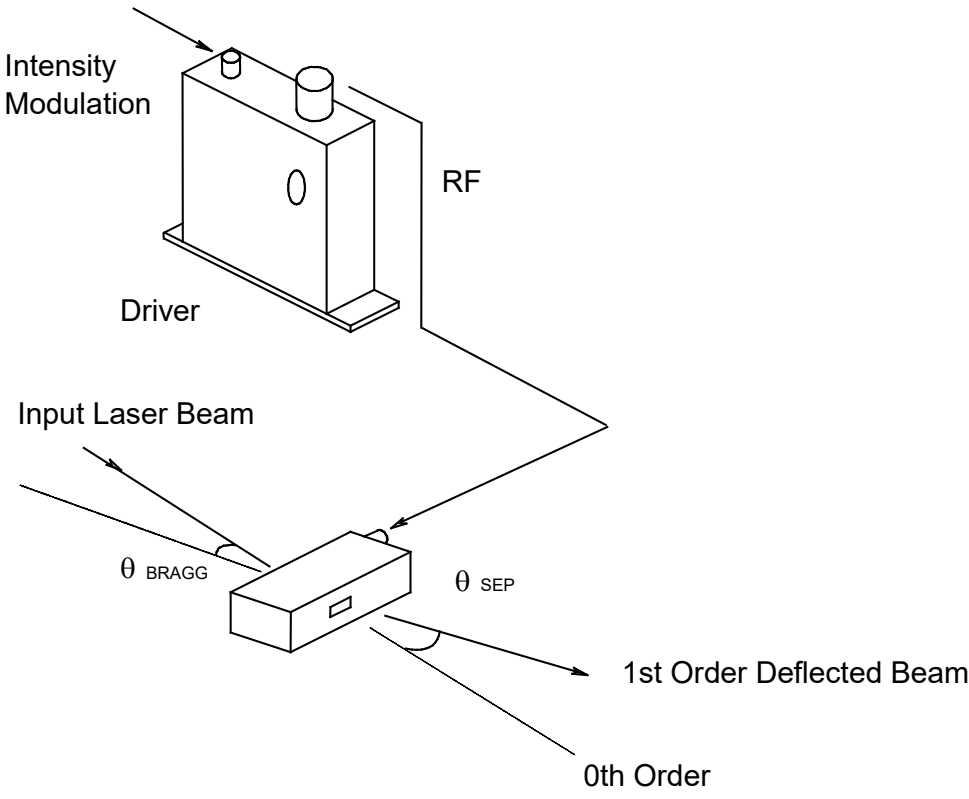

Figure 6: Possible Input Bragg Angle Orientations

Basic AO Modulator Parameters



The input Bragg angle, relative to a normal to the optical surface and in the plane of deflection is:

$$\theta_{BRAGG} = \frac{\lambda \cdot f_c}{2 \cdot v}$$

The separation angle between the Zeroth order and the First order is:

$$\theta_{SEP} = \frac{\lambda \cdot f_c}{v}$$

Optical rise time for a Gaussian input beam is approximately:

$$t_r = \frac{0.65 \cdot d}{v}$$

- where:
- λ = wavelength
 - f_c = centre frequency
 - v = acoustic velocity of interaction material
 - = 5.5mm/usec (Ge)
 - = 5.7mm/usec (Quartz)
 - = 5.96mm/usec (Fused Silica)
 - $d = 1/e^2$ beam diameter

Figure 7. Modulation System

Appendix A: Beam Position

Timing Considerations for AO Devices in Pulsed Lasers Applications

When attempting to synchronize a pulsed laser beam with a pulsed RF acoustic wave in an AO device, the designer must consider the transit time of the acoustic wave from the transducer to the laser beam position. This is called the *Pedestal delay*.

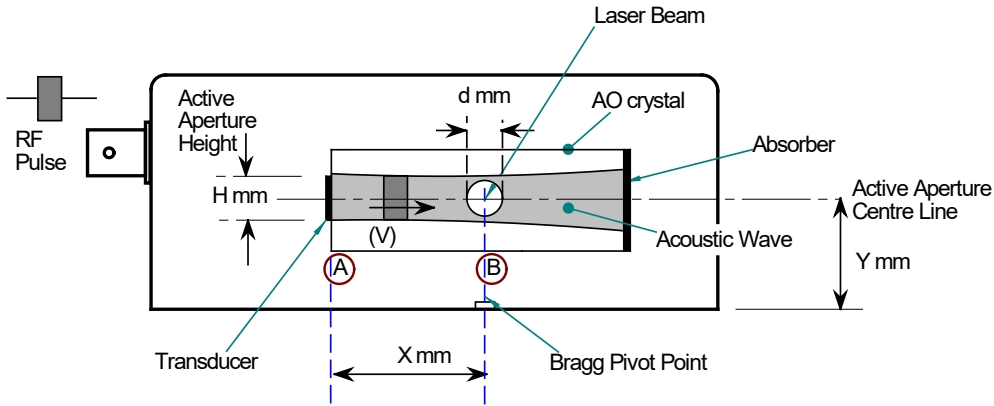

Input Beam Location

Vertical axis: Place the laser beam at the centre of the active aperture at Y mm above the base.
 Horizontal (Diffraction) axis: Place beam above the Bragg pivot point.

Timing considerations with respect to the RF modulation signal

An acousto-optic device is characterized by a travelling acoustic wave. This wave is launched from the RF excited transducer and travels at velocity V across the laser beam and into the absorber. It is important to consider this transit period when synchronizing a pulsed laser output with a pulsed AOM/AOD driver signal.

Early/late refers to the laser trigger timing relative to the RF driver modulation signal

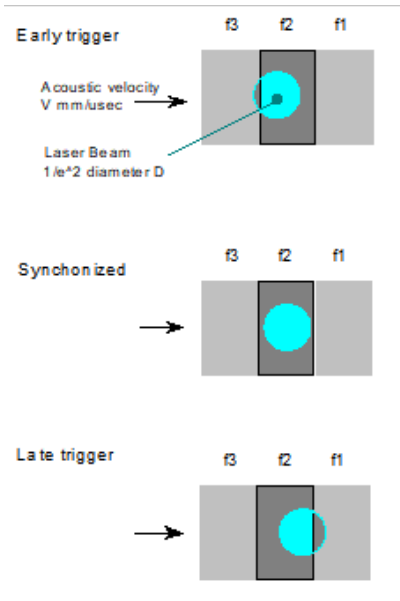

Pedestal delay

The time taken for the acoustic wavefront to reach the laser beam centre ⁽²⁾.

$T_p = \frac{\text{beam position from transducer (X)}}{\text{acoustic velocity (V)}}$

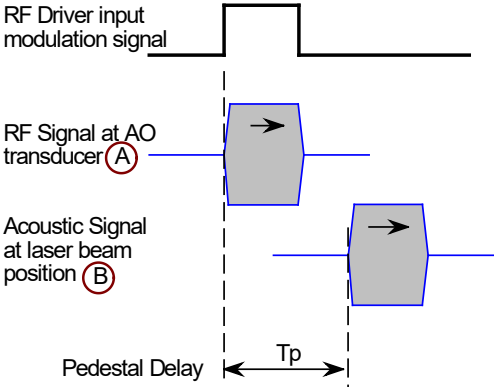

Transit time

The time taken for the acoustic wavefront to cross the entire laser beam diameter.

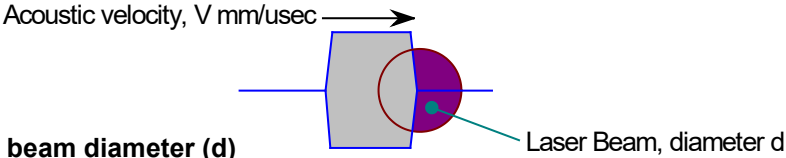

where: $T_t = \frac{\text{beam diameter (d)}}{\text{acoustic velocity (V)}}$

This equates to the minimum RF pulse width.

Optical rise / fall switching time

For a Gaussian beam is approximately $T_r = 0.65 \times T_t$

Total Sync Time

This represents the total delay time between the electronic modulation signal and the corresponding acoustic signal at the laser beam centred over the Bragg Pivot Point. This is given by :

$T_{st} = \text{Pedestal delay} + \frac{1}{2} \text{ pulse width duration}$

The minimum RF pulse width duration will depend on the beam diameter. See 'Transit Time' In the limiting case, pulse width duration = transit time.

Laser sync output

Please be aware, there may be an additional delay between the laser input trigger signal and the laser output pulse. This delay should also be considered when synchronizing.